

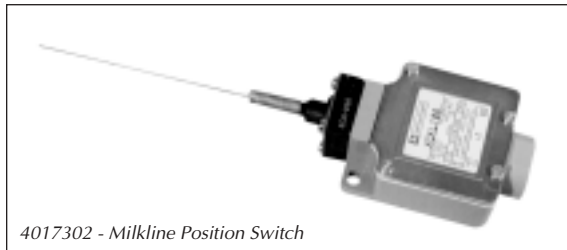

8510276 - Kit, Guardian Washer



4017302 - Milcline Position Switch

Guardian Pipeline Washer

CSA, UL and CE tested, 230V, 50/60 Hz. Guardian Washer includes: control module with LCD display, pump module with three chemical pumps, 50 feet (15 meters) of chemical dispensing tubing, pressure switch level sensor, electric drain valve, and chemical tube support assembly.

Part No.	Description
8510276	Guardian Washer

Note: The positive displacement chemical pumps provided with the Guardian Washer have a maximum dispense rate of 7 oz. (200 ml) per minute. There is no provision to add an additional pump or a larger pump. Intended for concentrated detergent only.

Complete Guardian Deluxe Assemblies

Assemblies include Guardian Washer (8510276), plus two water solenoid valves (normally closed), stainless steel diverter valve (8518558), and air injector valve (8503938).

Part No.	Description
8512074	Kit, Guardian, Complete, Deluxe, 1/2" water valves
8512075	Kit, Guardian, Complete, Deluxe, 3/4" water valves
8512076	Kit, Guardian, Complete, Deluxe, 1/2" water valves less air injector valve
8512077	Kit, Guardian, Complete, Deluxe, 3/4" water valves less air injector valve

Complete Guardian Economy Assemblies

Assemblies include Guardian Washer (8510276), plus two water solenoid valves (normally closed), plastic diverter valve (8506294), and air injector valve (8503938).

Part No.	Description
8510722	Kit, Guardian, Complete, Economy, 1/2" water valves
8510723	Kit, Guardian, Complete, Economy, 3/4" water valves
8511498	Kit, Guardian, Complete, Economy, 1/2" water valves less air injector valve
8511499	Kit, Guardian, Complete, Economy, 3/4" water valves less air injector valve

Accessories

Milcline Position Switch

Safety switch used to prohibit operation of a pipeline washer before the system is set up to wash.

Part No.	Description
4017302	Milcline Position Switch

Contactor

40 Amp, 2-pole, needed if Guardian is used with more than one pulsation controller, to prevent overloading Guardian control.

Part No.	Description
4012938	Contactor, 40 Amp, 2-pole, 240V

GUARDIAN II PIPELINE WASHER

Guardian II Pipeline Washer

CSA, U. L., and CE approved 230V, 50/60 Hz. Guardian II Assembly includes: control module with LCD screen, pump module with three chemical pumps, packed parts including the temperature sensor, and 100 feet of chemical dispensing (polyethylene) tubing

Part No.	Description
8516983	Guardian II Assy. without water valves

Note: Must also order drain valve (230V), diverter valve (230V), and water solenoid valves.

Guardian II Assemblies with Water Solenoid Valves

Assemblies include Guardian II Assy. (8516983), plus two water solenoid valves (normally closed), 230V, 50/60 Hz.

Part No.	Description
8516325	Guardian II with two 1/2" water valves
8515270	Guardian II with two 3/4" water valves

Note: Must also order drain valve (230V) and diverter valve (230V).



8516983 - Guardian II Pipeline Washer

Complete Guardian II Assemblies

Assemblies include Guardian II Assy. (8516983), plus two water solenoid valves (normally closed), stainless steel diverter valve (8518594), 230V, and electric drain valve (8518176), 230V, and one rubber coupling (8517737).

Part No.	Description
8512078	Guardian II Assy. Complete, 1/2" water valves
8512079	Guardian II Assy. Complete, 3/4" water valves
8512080	Guardian II Assy. Complete, 1" water valves
8512081	Guardian II Assy. Complete, 1.5" water valves
8512082	Guardian II Assy. Complete, 2" water valves

Note: Positive displacement chemical pumps provided with all Guardian II assemblies have a maximum run time of five minutes, and can dispense a maximum of 22 oz. per minute at 60 Hz (or 540 ml per minute at 50 Hz). If you need to dispense more than 110 oz. (2700 ml) see the next page to order extra chemical pumps for detergent.

Guardian II Control Less Pump Module

Part No.	Description
8504101	Guardian II Control without pump module

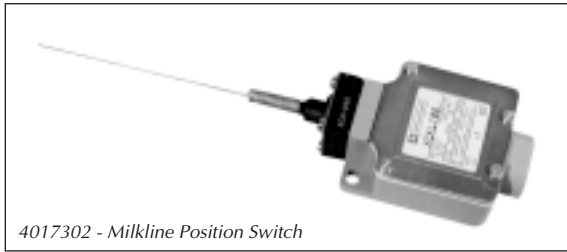

4017302 - Milcline Position Switch

Milcline Position Switch

Safety switch used to prohibit operation of a pipeline washer before the system is set up to wash.

Part No.	Description
4017302	Milcline Position Switch



8515276 - Remote Start Kit

Remote Start Kit

Includes switch and lamp. Allows user to start the wash or sanitize cycle at a point away from the Guardian II control module. Order two remote start kits if both wash cycle and sanitize cycle will be remote started. Dealer must supply enclosure.

Part No.	Description
8515276	Remote Start Kit

Norprene Hose

1/4 inch ID, replacement hose for positive displacement pumps. Hose needs to be replaced annually.

Part No.	Description
8515267	Norprene Hose—1/4" ID, 25' roll
8516164	Kit, (3) 10" long Norprene Hoses



8515262 - Extra Chemical Pump

Contactor

40 Amp, 2-Pole needed if Guardian II is used with more than one pulsation controller, to prevent overloading Guardian II control module.

Part No.	Description
4012938	Contactor—40 Amp, 2-Pole

Extra Chemical Pump

For systems requiring more than 110 oz. (2700 ml) of detergent dispensed per wash cycle. Enclosure not included.

Part No.	Description
8515262	Extra Chemical Pump

Note: Each chemical pump can dispense approximately 22 oz. per minute at 60 Hz (or at 50 Hz approximately 540 ml per minute) and has a maximum run time of 5 minutes.



3556397 - Serial Printer

Air injectorAccessories

Part No.	Description
8514091	Transformer, 230/26V (Allows Guardian II to be the air injector control.)
8503938	Cyclone Air Injector less Controller

Hand Held Serial Printer

For dealer diagnostic use, or for on-farm use. Includes: power supply and RS-232 serial cable assembly used to connect Guardian II control module to the serial printer.

Part No.	Description
3556397	Serial Printer, 115V
3556421	Serial Printer, 230V

DARI-CHEM AND GUARDIAN I WASHER ACCESSORIES

Dari-Chem Programmable Liquid Chemical Dispensing Unit

Three independently programmable peristaltic pumps economically dispense chemicals for a pipeline washer.

Dari-Chem Dimensions

6"h x 13.75"w x 6.75"d (15.2 cm x 35 cm x 17 cm)

Part No	Description
8502705	Dari-Chem Pipeline Washer Kit with Fill Switch and Support Arm Kit

Detergent Cycle Timer Kit

Designed to be used with Bou-Matic PW-100 and Guardian I Pipeline Washers. Allows you to adjust the detergent cycle time anywhere from four minutes to the normal length of time. When this relay is activated, the vacuum pump is turned off, and the drain is opened for the remainder of the detergent circulation time.

Part No.	Description
8507311	Detergent Cycle Timer, 230V
8507312	Detergent Cycle Timer, 115V

Wash Jars

Two quart jar for large capacity system where a powdered detergent is used. One quart jars can be used to replace glass wash jars. Both jars fit PW-100, Guardian I, and Deco-Matic III (DKF controllers).

Part No.	Description
8505069	Polysulfone Jar, Two Quart
4018856	White Plastic Jar, One Quart



8502705 - Dari-Chem Pipeline Washer Kit



8506294 - Diverter Valve, Plastic



8518594 - Diverter Valve, Stainless

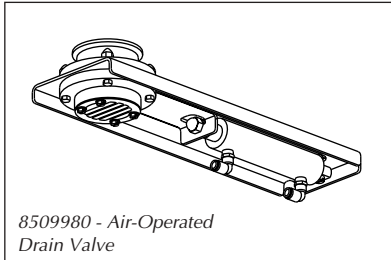

8509980 - Air-Operated Drain Valve



8518176 - Electric Drain Valve



8503075 - 0.5" Water Solenoid Valve

Diverter Valves

Used to divert wash solution during recirculation or during clear water rinse phases. Mounts on sink.

Plastic Diverter Valves

Note: Valves are not CSA approved. On-site inspection is required for Canada.

Part No.	Description
8506294	Diverter Valve, 230V, 60 Hz, 1.5" inlet and 2" (5.1 cm) OD outlet
8505085	Diverter Valve, 115V, 60 Hz, 1.5" inlet and 2" (5.1 cm) OD outlet.
8502796	Diverter Valve, 230V, 50 Hz, 1.5" inlet and 2" (5.1 cm) OD outlet.

Stainless Steel Diverter Valves

8518594	Diverter Valve, stainless, electric, 230V, 50/60 Hz, 2" (5.1 cm) inlet
8518558	Diverter Valve, stainless, electric, 230V, 50/60 Hz, 1.5" inlet

Air-Operated Drain Valves

Mounts on sink with a 2" milliline clamp and gasket. Kit includes 230VAC air solenoid, connectors, clamp and gasket.

Part No.	Description
8510269	Kit, Sink Drain, Air-Operated
8509980	Air-Operated Drain Valve only

Electric Drain Valves

Normally open drain valves UL listed and CSA approved. 230V, 50/60 Hz.

Part No.	Description
8518176	Electric Drain Valve 2" (5.1 cm), 230V, 50/60 Hz
8517737	Rubber Coupling w/Hose Clamps (1.5" nominal or 2" (5.1 cm) OD pipe outlets)
8518177	Electric Drain Valve 3" 230V, 50/60 Hz
8518671	Rubber Coupling w/o Hose Clamps (2.5" nominal or 3" OD pipe outlets)
8514035	Hose Clamp for 8518671 coupling (order two per coupling)

Water Solenoid Valves

Normally closed valves, 230V, 50/60 Hz.

Part No.	Description
8503075	0.5" Water Solenoid Valve
8503076	0.75" Water Solenoid Valve
8503077	1.0" Water Solenoid Valve
8503078	1.5" Water Solenoid Valve
8503079	2.0" Water Solenoid Valve

Metric Adapters (Brass)

Part No.	Description
8551183	Adapter, 3/4" - 14 ISO Parallel to 3/4" NPT (male)
8515762	Adapter, 1" NPT to 1" ISO Tapered (male)

Cyclone Air Injector System

The Cyclone air injector system produces soil-loosening turbulence and slugging impact for high-velocity milkline cleaning.

- Adjustable for up to 300 CFM capacity at 15" Hg vac.
- Full 2" (5.1 cm) connection
- Independently adjustable on and off times
- Resettable circuit breaker switch to protect components
- Foam-type filter keeps insects and contaminants out of the system during cleanup
- 230 VAC controller input, 50/60Hz
- CSA and CE approved.

Cyclone Air Injector System, Complete

For use on any existing wash system. Consists of air injector controller (PN 8518532) and air injector (PN 8503938).

Part No.	Description
8506243	Cyclone Air Injector System

Air Injector Controller Only

Input: 230V, 50/60 Hz

Output: 24V, 50/60 Hz

Capacity: Two Cyclone air injectors

Part No.	Description
8518532	Air Injector Controller Only

Cyclone Air Injector Only

Includes: Cyclone air injector, filter, adapter coupling, and clamps. Controller not included.

Part No.	Description
8503938	Cyclone Air Injector

Parlor-Mount Adapter

Part No.	Description
8504002	Parlor-Mount Adapter, mounts air injector directly to milk line

Cyclone Air Injector Filter Kit

Upgrades older Cyclone air injectors without foam air filter. Clear cover not included.

Part No.	Description
8503024	Air Injector Filter Kit
8503904	Drip-proof cover, Air Injector

Cyclone System, Retrofit Kit

For complete retrofitting of 8513850 master control panels (built before 5/1/79) with old-style solenoid-operated air injector and mechanical controller. Kit includes: Cyclone Air Injector, repeat cycle timer and power supply with bracket for mounting in control panel, adapter coupling, clamps, and instructions.

Part No.	Description
8506245	Cyclone System Retrofit Kit



8518532 - Cyclone Air Injector Controller



8503938 - Cyclone Air Injector



8504002 - Parlor-Mount Adaptor

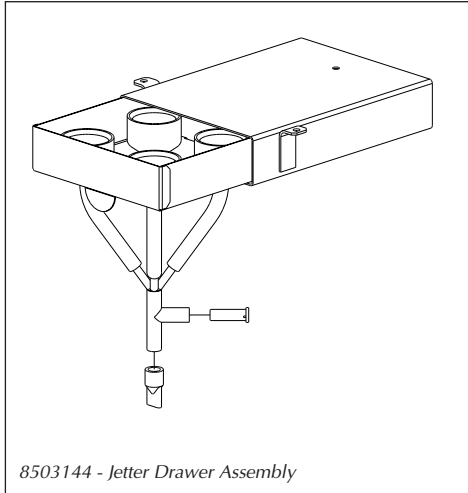

8503144 - Jetter Drawer Assembly

Jetter Drawer Assembly

Used in parlors for clean-in-place washing of milking units, and stores out of the way during milking. Assembly includes jetter cups, stainless distributor tee, duckbill drain valve, restrictor orifice and a stainless steel hook to position claw during washing.

Part No.	Description
8503144	Jetter Drawer Assembly, R-Series/Stretch Cap
8503145	Jetter Drawer Assembly, RM-1/DK Liner
8510949	Jetter Drawer Assembly, M-Series/Competitive
8503022	Rubber Jetter Cup, R-Series/Stretch Cap
8503023	Rubber Jetter Cup, RM-1/DK Liner
8510176	Rubber Jetter Cup, M-Series/Competitive

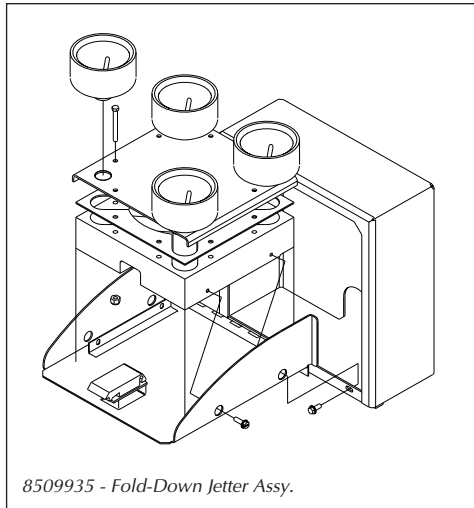

8509935 - Fold-Down Jetter Assy.

Fold-Down Jetter

Designed for parlors with a platform overhang too small to allow the use of the jetter drawer. It features:

- Stainless steel door and enclosure.
- Latch holds door closed during milking.
- Compact - 8-1/2" W x 9-1/8" H x 3-1/2" D (216 x 232 x 89 mm) when folded up.
- Rubber jetter cups (8503691) fit most Bou-Matic liners

Not included with the jetter:

- Restrictor orifice, wash line (8518076)
- Claw support, dealer fabricated, if required
- Automatic drain(s)

Part No.	Description
8509935	Fold-Down Jetter Assy.
8503691	Rubber Jetter Cup, Short, R-Series/Stretch Cap
8510177	Rubber Jetter Cup, Short, M-Series/Competitive

Standard Jetter Assembly and Parts

Used in parlors or flat barns for clean-in-place washing of milking units. Each assembly includes a stainless steel holder, a stainless distributor tee with air vent, jetter cups, and drain valve. Order the in-line restrictor to balance flow in larger systems.

Part No.	Description
8514751	Jetter Assembly Complete with Holder
8518076	Jetter In-Line Restrictor
8514752	Stainless Distributor Tee w/.078" (2mm) Vent
8514721	Plastic Distributor w/.078" (2mm) Vent
8514719	Plastic Tee
8517844	Duckbill Check Valve
8514723	Rubber Jetter Cup, Original Style
8503022	Rubber Jetter Cup, R-Series/Stretch Cap
8503023	Rubber Jetter Cup, RM-1/DK Liner
8510176	Rubber Jetter Cup, Magnum Series/Competitive

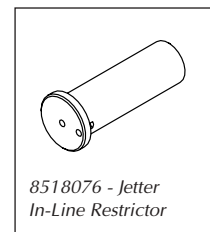
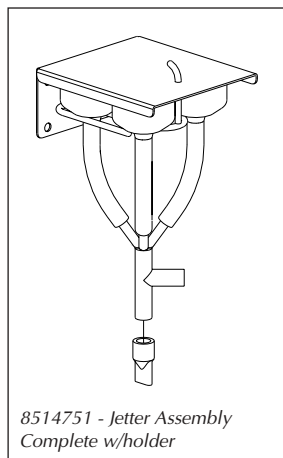

Wash Line Accessories

Restrictors are intended to be installed between the air injector and the wash sink. Wash line restrictor kit includes two each of various hole sizes of 1.5 and 2" stainless washers.

Part No.	Description
8515564	Wash Line Restrictor Kit, 1.5 and 2"
8516235	1.5" (38 mm) Wash Line Restrictor, .19" (4.7 mm) ID (bag of 10)
8516236	2" (51 mm) Wash Line Restrictor, .19" (4.7 mm) ID (bag of 10)
8509818	3" Wash Line Restrictor Kit, (one each of five sizes)
8515628	Suction Line Check Valve, 2", Plastic

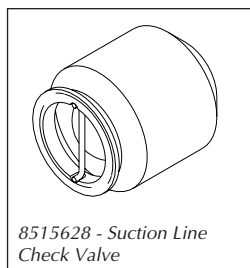
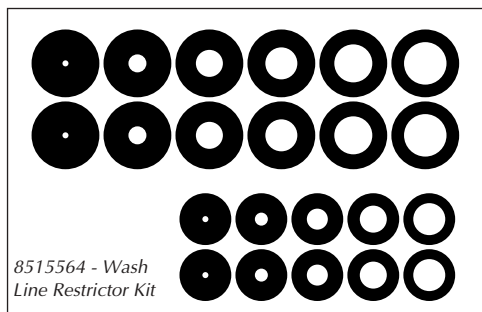

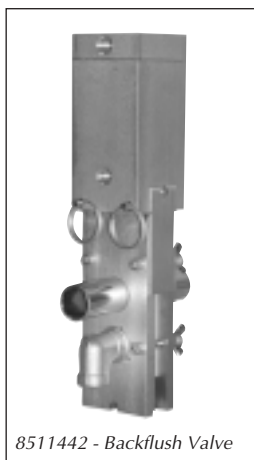

8511442 - Backflush Valve

Sure-San Backflush Valve

Use one valve per stall for use in a group flush system. May be used with any brand detacher. Mounting brackets are dealer-supplied. 9-1/4"h X 2"w X 2"d (23.5 cm X 5.1 cm X 5.1 cm).

Part No.	Description
8511442	Valve, Backflush

Releaser Assembly

For collection and removal of fluids in group backflush systems. Includes vacuum valves, releaser and gate valve assembly. Not required when water ring-type vacuum pump is used. Order one per 12 units.

Part No.	Description
8509971	Releaser Assembly, Stainless Steel Body



8516962 - Auto Start Valve

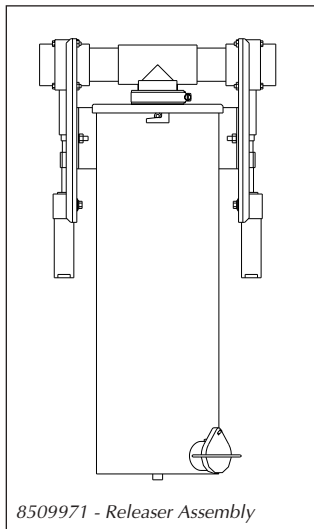

8509971 - Releaser Assembly

Claw Backflush Hangers

Mount over claw outlet so claw rotates upside down for backflushing.

Part No.	Description
3553288	Hanger, 5/8" (16 mm) Visi-Claw outlet
3553452	Hanger, 3/4" (19 mm) Visi-Claw outlet or 5/8" (16 mm) Flo-Star Claw outlet
3557788	Hanger, 3/4" (19 mm) Flo-Star Claw outlet

Milk Sweep Valve

Removes residual milk from the claw and milk hose prior to backflushing.

Part No.	Description
8515896	Kit, Milk Sweep Valve (order 1 per detacher)

Important: Milk sweep cannot be used with 3000D or 3000M detachers.

Gate Valve Assembly

Used where a water ring-type vacuum pump is substituted for releaser assembly. Order one per bank of units to be flushed simultaneously.

Part No.	Description
3553999	Gate Valve Assembly

Auto Start Valve

Used to provide an automatic start pulse for the group backflush after all units have been detached. Order one valve for each detacher.

Part No.	Description
8516962	Valve, Auto Start, 5/32" (5.1 cm)

Sample Order, Backflush

Qty	Part No.	Description
24	8511442	Valve, Backflush
24	3556147	Space Saver Hose, 12" w/3/4" (19mm) ends
2	3554044	Control, Backflush (1 per 12 valves)
2	8509971	Releaser Assembly
10	3554043	Bracket, Mounting, PVC (as needed)
24	3553452	Hanger, Claw, Backflush
24	8515896	Kit, Milk Sweep Valve (1 per detacher w/o separate valve for shutoff)
1	3554142	Power Supply, 12-unit

Dealer Supplied Items

- Chemical pump, mixing chamber (water filter housing)
- Back Flow Preventer, RPZ
- Separate vacuum supply (6.5 cfm per unit)
- 5/32" (4.0 mm) air tubing (as needed)
- 3/8" (4.5 mm) poly. tubing (3553413 as needed)
- Compressed air supply
- Backflush valve mounting bracket (24)
- 1.5" (38.1 mm) schedule 80 PVC (as needed)
- 1" (25.4 mm) schedule 80 PVC (as needed)

GROUP BACKFLUSH

Sure San Group Backflush Control

Provides control of backflush timing cycles for valve boxes, solutions and releaser. Includes control and four fluid valves. May be used to control up to two groups with up to six units per group. Order one per 12 valve boxes. (Uses system power supply).

Part No.	Description
3554044	Control Assembly w/four chemical valves
3554773	Air Operated Chemical Valve, 1" NPT
8509990	Control Assembly less chemical valves

Dealer Supplied Parts:

- Water pressure of 45 PSI to panel throughout cycle
- Vacuum supply including gauge, trap and regulator (6.5 cfm/unit)
- Mounting hardware for controls, fluid mixing panel, valve boxes and fluid and airlines
- Water supply plumbing
- Power Supply (see Information Management System catalog section for load ratings)
- RPZ backflow preventer

Pipe Mounting Bracket

For maintaining support beneath the curb for valve control lines and fluid manifold. Holds two 3/4 inch and one 1 inch pipes. Order one per 4 feet of PVC pipe.

Part No.	Description
3554043	Pipe Mounting Bracket, Triple

Space Saver Hose

This hose prevents pinching of milk hose. 5/8" (16mm) inside diameter.

Part No.	Description
3556147	Space Saver Hose, 12" with 3/4" (19mm) ends



3554773 -
Air Operated
Chemical Valve



8509990 - Control Assembly

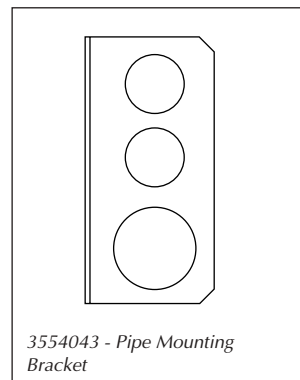

3554043 - Pipe Mounting
Bracket

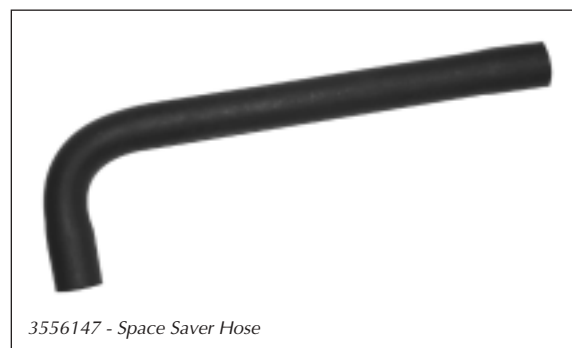

3556147 - Space Saver Hose



8590110 - Single Compartment Sink

Single Compartment Sinks

Complete with drain hardware. Order mounting kits separately.

Part No.	Length	Capacity
8590110	22"	18 gallon
8590045	29"	23 gallon
8590200	36"	29 gallon
8590111	49"	39 gallon
8590181	60"	48 gallon
8590180	72"	57 gallon

Double Compartment Sinks

Complete with drain hardware. Order mounting kits separately.

Part No.	Length	Capacity
8590043	22"/22"	36 gallon
8590044	29"/29"	46 gallon

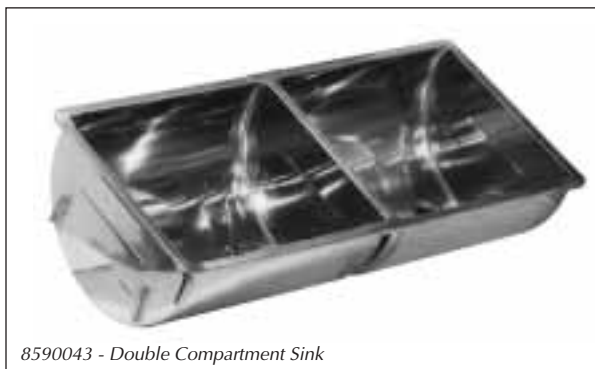

8590043 - Double Compartment Sink

Floor Stand Leg Kit

For use on standard single and double compartment sinks. Kit includes two leg brackets and mounting hardware. Brackets are 33-3/8 inch high; sink top will be 33-1/2 inch from the floor.

Part No.	Description
8590048	Floor Stand Leg Kit

Wall Mounting Bracket Kit

For use on standard single and double compartment sinks listed above. Kit includes two brackets.

Part No.	Description
8590049	Wall Mounting Bracket Kit



8590048 - Floor Stand Leg Kit



8590049 - Wall Mounting Bracket Kit

WASH SINKS

Large Capacity, Single Compartment Sinks

Intended for wall mount only, using large capacity bracket kit listed below.

Part No.	Description	Capacity
8590178	21.5" x 13.5" deep x 85" long	82 gallon
8590179	21.5" x 13.5" deep x 97" long	93 gallon

Wall Mounting Bracket Kit, Large Capacity

Intended for use only with large capacity, single compartment sinks listed above. Kit includes two brackets.

Part No.	Description
8590177	Wall Mounting Bracket Kit

Stallcock Wash Tube

Order in multiples of five.

Part No.	Description
8512200	Stainless Steel Tube—5/8" diameter x 3"

Pulsator Wash Racks

Part No.	Description
8518215	Pulsator Wash Rack, Four Unit
8518216	Pulsator Wash Rack, Six Unit

Claw Hanger Bracket

For mounting on sink to hold Flo-Star claw in proper position during washup.

Part No.	Description
8506882	Hanger, Adjustable

Vertical Wash Sinks

Space saving vertical wash sink, especially for large capacity systems. Reduced surface heat loss compared to horizontal style sinks. Sturdy, notched leg design, leg anchors, adjustable stainless feet, and external sight tube. Made of 16 gauge stainless, the interior finish is no. 4 with the exterior finish being a no. 3, which will meet sanitary requirements. All sizes come with a 2 inch straight drain outlet. All sinks are 28.5 inch in diameter. Stainless lids not included.

Part No.	Description
8517775	Vertical Sink, 99 Gallon, 55" tall
8517776	Vertical Sink, 132 Gallon, 67" tall
8517777	Vertical Sink, 163 Gallon, 79" tall
8517778	Sink Lid, Blank, Flat
8517779	Sink Lid, Blank, Hinged

Note: Custom sink lids with extruded holes are available for vertical wash sink. Please contact the Customer Service Department for a price quote. Order form on next page must be used to order the custom lid.



8590178 - Large Capacity, Single Compartment Sink



8590177 - Wall Mounting Bracket Kit



8512200 - Stainless Steel Tube



8518215 - Parlor Wash Rack

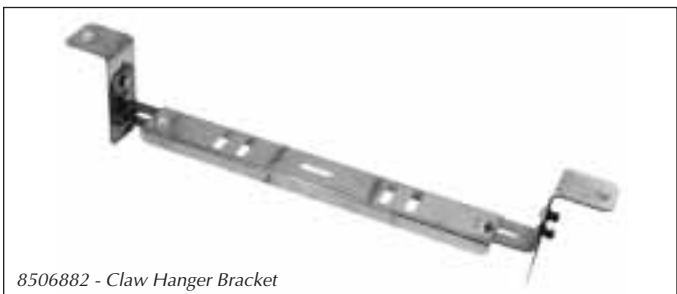

8506882 - Claw Hanger Bracket



8517779 - Hinged Sink Lid for Vertical Wash Sink

Vertical Wash Sink Custom Lid Special Order Form

This order form must be completed and submitted for all customized stainless vertical wash sink lids.
Only one sink lid per order form. Please make copies of this form as needed.

Dealer Name _____ Dealer Number _____

PO Number _____ Date Ordered ____/____/____ Date Required ____/____/____

1. Select stainless lid style: ____ Hinged lid with handle ____ Flat lid without handle

2. Size and number of pull outs:

Pullout No.	Size	Offset From Edge (A)	Offset From Edge (B)
1.			
2.			
3.			
4.			
5.			

Note: Available sizes of pullouts include 1.5, 2, 2.5 and 3 inch (3.8, 5.1, 6.4 and 7.6 cm). Offsets are measured to center of pullout. For Bou-Matic plastic diverter valve use a 2.38 inch (6.05 cm) offset from edge. For a Bou-Matic stainless steel diverter valve, use 6.12 inch (15.54 cm) offset from edge.

3. Diagram position of pullout

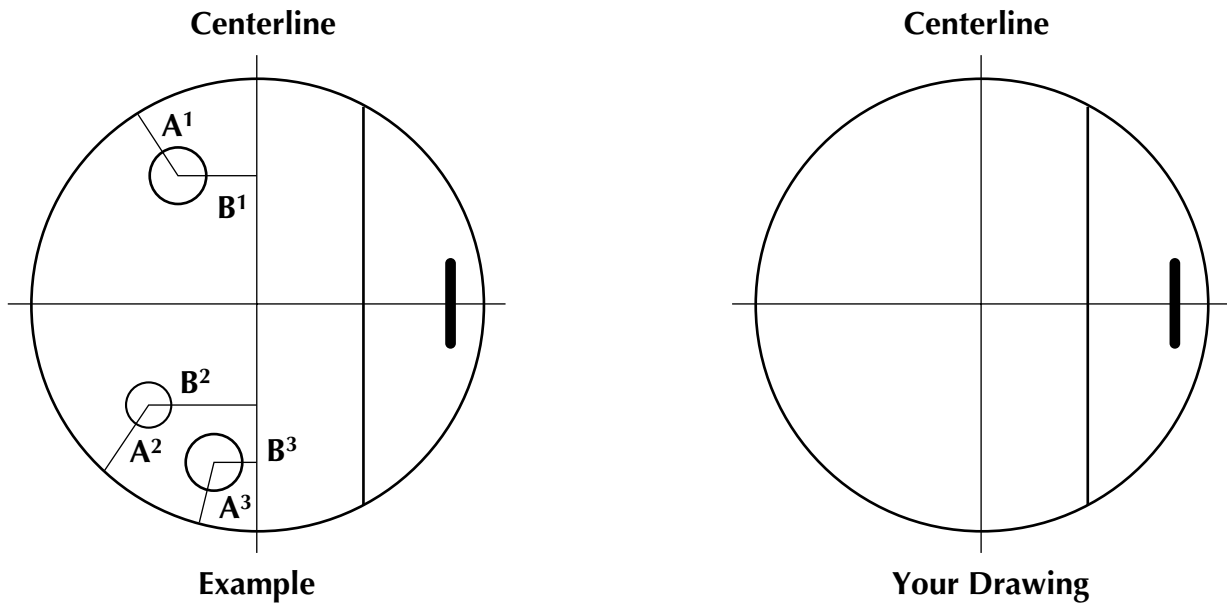

FOR OFFICE USE ONLY:

Sales Order # _____ Date Received ____/____/____

Purchase order # _____ Ship with Sales Order # _____